

**TRANSMISSION
PARTS LIST
Spicer ES43-5**



Bulletin No. T210-ES43-5

March 2000



MODEL ES43-5

CONTENTS, RATIO TABLE and IDENTIFICATION

T210-ES43-5

CONTENTS

RATIO TABLE	1
GEARS AND RELATED PARTS	2-5
DRIVE GEAR GROUP	2-3
MAINSHAFT GROUP	2-3
COUNTERSHAFT GROUP	4-5
REVERSE IDLER SHAFT GROUP	4-5
DRIVE GEAR TABLE	5
DRIVE GEAR BEARING CAP CHART WITH CLUTCH APPLICATIONS	6
CLUTCH HOUSING & DRIVE GEAR BEARING CAP GROUP	6-7
CLUTCH HOUSING DIMENSIONS	7
CASE GROUP	8-9
REAR BEARING CAP CHART WITH BRAKE APPLICATIONS	10
REAR BEARING CAP GROUP AND RELATED PARTS	10-11
REMOTE CONTROL ASSEMBLY	12
COMPANION FLANGES AND END YOKES	13
SHIFT BAR AND FORK ASSEMBLY	14
SHIFT LEVER AND DOME ASSEMBLY	15
CLUTCH RELEASE PARTS AND DIMENSIONS	16-17
OVERHAUL KITS—MAJOR AND MINOR	18-19
TABULATED BILLS OF MATERIALS	20-23
BACK-TAPER CHANGEOVER KITS	24

RATIO TABLE

SPEEDS	MODELS	
	ES43-5A	ES43-5D
1st	7.25	7.25
2nd	3.98	3.98
3rd	2.23	2.23
4th	1.44	1.29
5th	1.00	1.00
Rev.	6.77	6.77

Parts listed in this catalog may no longer be available. Use with transmission superseding list.

IDENTIFICATION

The Name Plate (NP-96) affixed to the RIGHT side of the Transmission is stamped with information:

Abbreviations used in this parts list include:

N.S. — Not Shown
 N.S.S. — Not Sold Separately
 N.R. — Not Required

SERIAL

B/M No. MODEL

In requesting more information on these transmissions, furnish the B/M No. and the Serial Number.

MODEL ES43-5

GEARS and RELATED PARTS

T210-ES43-5

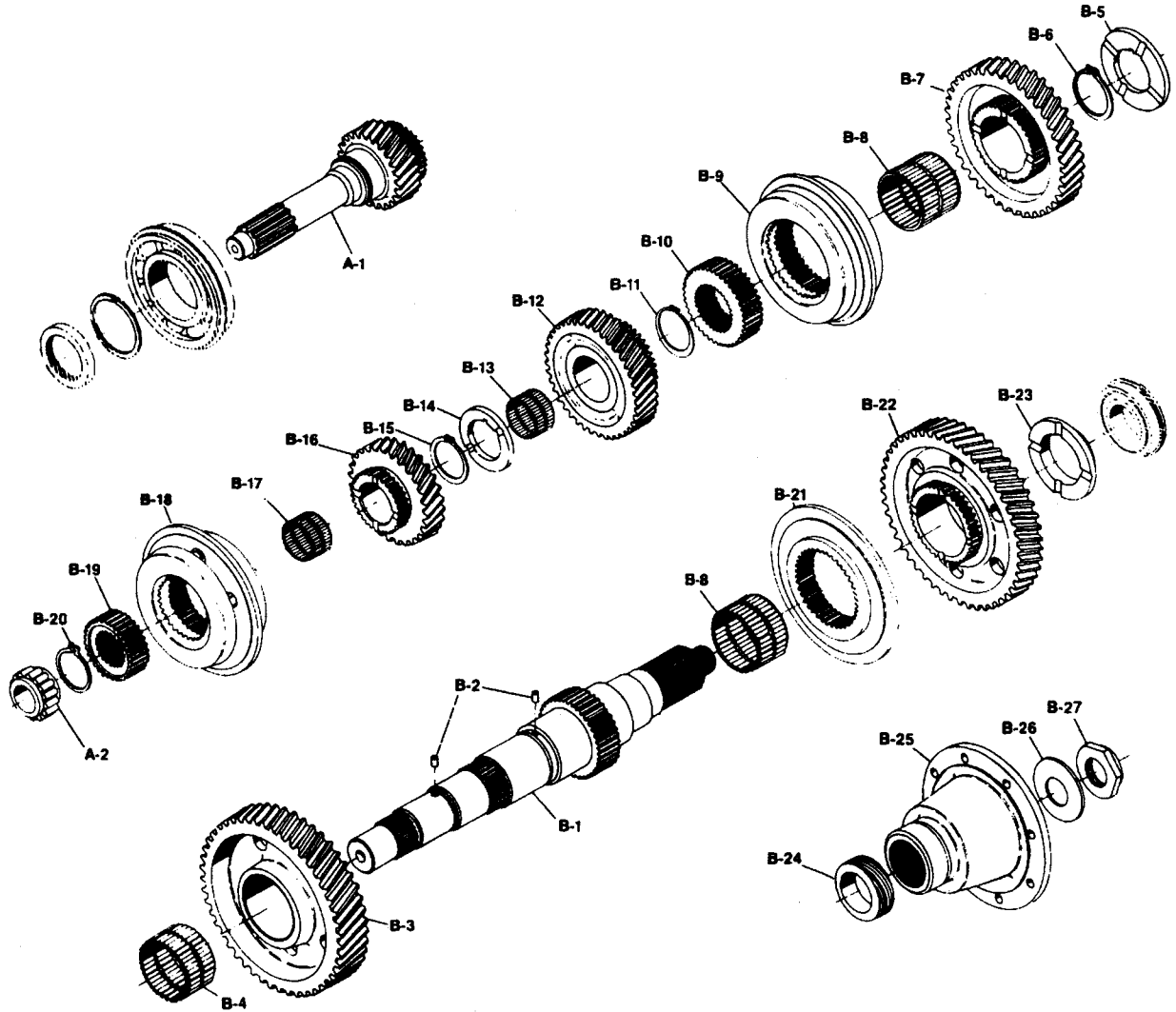

EASY SHIFT 5 SPEED MODELS (430 lb-ft)

GEARS and RELATED PARTS

T210-ES43-5

Ref. No.	Part No.	Description	Qty.
Drive Gear Group			
A-1	See Tab Bills	Drive Gear - Input (see table page 5)	1
A-2	550986	Bearing - Mainshaft Pocket	1
Mainshaft Group - Output			
B-1	49-362-1	Mainshaft	1
B-2	545087	Pin - Thrust Washer Lock	2
B-3	49-8-3	Gear - 1st Speed Mainshaft (45T)	1
B-4	550991	Bearing - 1st Speed Needle	1
B-5	49-47-1	Washer - 1st & 2nd Speed Thrust	1
B-6	49-381-1	Snap Ring - 1st & 2nd Thrust Washer	1
B-7	49-8-21	Gear - 2nd Speed Mainshaft (38T)*	1
or	49-8-5	Gear - 2nd Speed Mainshaft (38T)**	1
B-8	550963	Bearing - 2nd & Reverse Needle	2
B-9	49-464-1X	Synchronizer - 2nd & 3rd Mainshaft*	1
or	313764X	Synchronizer - 2nd & 3rd Mainshaft**	1
B-10	101-466-7	Gear - 2nd & 3rd Mainshaft Clutch*	1
or	101-466-4	Gear - 2nd & 3rd Mainshaft Clutch**	1
B-11	40-381-4	Snap Ring - 2nd & 3rd Clutch Gear	1
B-12	49-8-20	Gear - 3rd Speed Mainshaft (34T)*	1
or	49-8-7	Gear - 3rd Speed Mainshaft (34T)**	1
B-13	550968	Bearing - 3rd Speed Gear	1
B-14	49-47-2	Washer - 3rd & 4th Speed Thrust	1
B-15	40-381-3	Snap Ring - 3rd & 4th Thrust Washer	1
B-16	49-8-18	Gear - 4th Speed Mainshaft (22T) (for ES43-5A)*	1
or	49-8-9	Gear - 4th Speed Mainshaft (22T) (for ES43-5A)**	1
or	49-8-19	Gear - 4th Speed Mainshaft (21T) (for ES43-5D)*	1
or	49-8-11	Gear - 4th Speed Mainshaft (21T) (for ES43-5D)**	1
B-17	550990	Bearing - 4th Speed Gear	1
B-18	101-464-1X	Synchronizer - 4th & 5th Mainshaft*	1
or	313775X	Synchronizer - 4th & 5th Mainshaft**	1
B-19	49-466-4	Gear - 4th & 5th Speed Clutch (33T)*	1
or	101-466-2	Gear - 4th & 5th Speed Clutch (33T)**	1
B-20	40-381-1	Snap Ring - 4th & 5th Speed Clutch Gear	1
B-21	101-465-7	Clutch Collar - 1st & Rev.	1
B-22	49-8-13	Gear - Reverse (42T)	1
B-23	101-47-4	Washer - Reverse Thrust	1
B-24	See Tab Bills	Gear - Speedometer Drive	1
B-25	See Tab Bills	Companion Flange or End Yoke	1
B-26	53-205-1	Washer - Mainshaft Nut	1
B-27	501200	Nut - Mainshaft (1 1/4" - 18)	1

*-Back-Tapered Clutching Teeth Version (After Serial No. J960601000)

** - Straight Clutching Teeth Version (Before Serial No. J960601000)

N.S.S. - Not Sold Separately

◀◀◀◀ ◀◀◀◀ ◀◀◀◀ ◀◀◀◀ **IMPORTANT**

MODEL ES43-5

GEARS and RELATED PARTS

T210-ES43-5

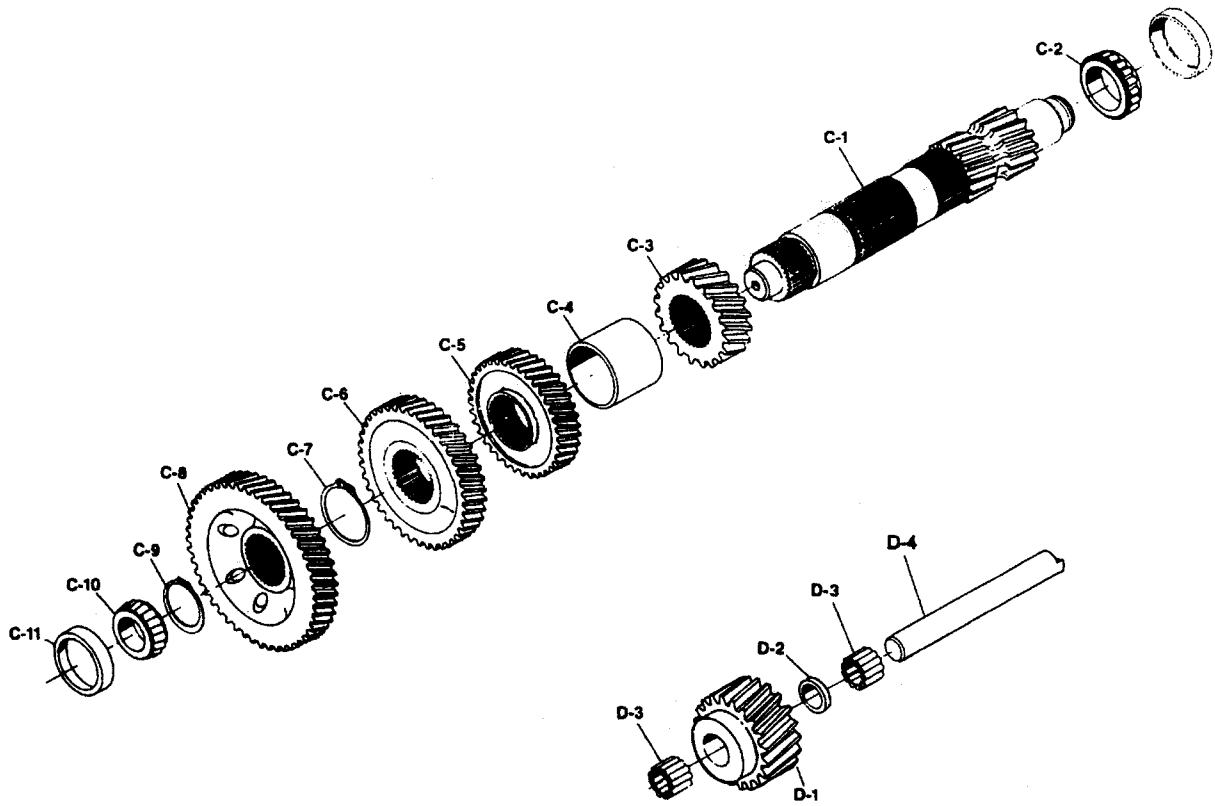

EASY SHIFT 5 SPEED MODELS (430 lb-ft) CASE GROUP and RELATED PARTS

T210-ES43-5

Ref. No.	Part No.	Description	Qty.
Countershaft Group			
C-1	49-30-7	Countershaft (without P.T.O. drive)	1
C-2	550868	Cone - Bearing - Countershaft Rear	1
C-3	49-196-1	Gear - 2nd Speed Countershaft (20T)	1
C-4	49-37-5	Spacer - 2nd & 3rd Speed Countershaft Gear	1
C-5	49-196-3	Gear - 3rd Speed Countershaft (32T)	1
C-6	49-196-5	Gear - 4th Speed, Countershaft (32T) for ES43-5A	1
or	49-196-7	Gear - 4th Speed, Countershaft (34T) for ES43-5D	1
C-7	27-381-5	Snap Ring - 4th Speed Countershaft Gear	1
C-8	49-1-1	Gear - Drive (44T) Countershaft	1
C-9	40-381-3	Snap Ring - Countershaft Drive Gear	1
C-10	550964	Cone - Bearing - Countershaft Front	1
C-11	550965	Cup - Bearing - Countershaft Front	1
Reverse Idler Group			
D-1	49-5-2	Gear - Reverse Idler (17T)	1
D-2	49-37-7	Spacer - Bearing Reverse Idler Gear	1
D-3	550886	Bearing - Reverse Idler	2
D-4	63-60-1	Shaft - Idler Gear	1

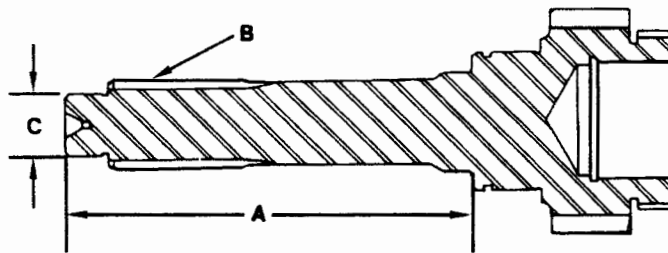

DRIVE GEAR TABLE

A Input Shaft Length	B Spline Dia. & No. of Teeth	C Pilot Size	Drive Gear Sub-Assembly (Includes 49-468-2)
6.40"	1.375"-10 spline	.9837"	49-35-1-1X**
9.93"	1.500"-10 spline	.9837"	49-35-3-1X**
7.22"	1.500"-10 spline	.9837"	49-35-5-1X**
7.99"	1.125"-10 spline	.5900"	49-35-10-1X**
9.93"	1.500"-10 spline	1.180"	49-35-11-1X**
6.40"	1.375"-10 spline	.9837"	49-35-16-1X*
9.93"	1.500"-10 spline	.9837"	49-35-17-1X*
7.22"	1.500"-10 spline	.9837"	49-35-19-1X*
9.87"	1.750"-10 spline	1.180"	49-35-20-1X*
9.93"	1.750"-10 spline	.9837"	49-35-21-1X*
7.99"	1.125"-10 spline	.5900"	49-35-22-1X*
9.93"	1.500"-10 spline	1.180"	49-35-23-1X*

*-Back-Tapered Clutching Teeth Version (After Serial No. J960601000)

** - Straight Clutching Teeth Version (Before Serial No. J960601000)

N.S.S. - Not Sold Separately

◀◀◀◀◀◀◀◀◀ **IMPORTANT**

MODEL ES43-5

CLUTCH HOUSING and DRIVE GEAR BEARING CAP GROUP

T210-ES43-5

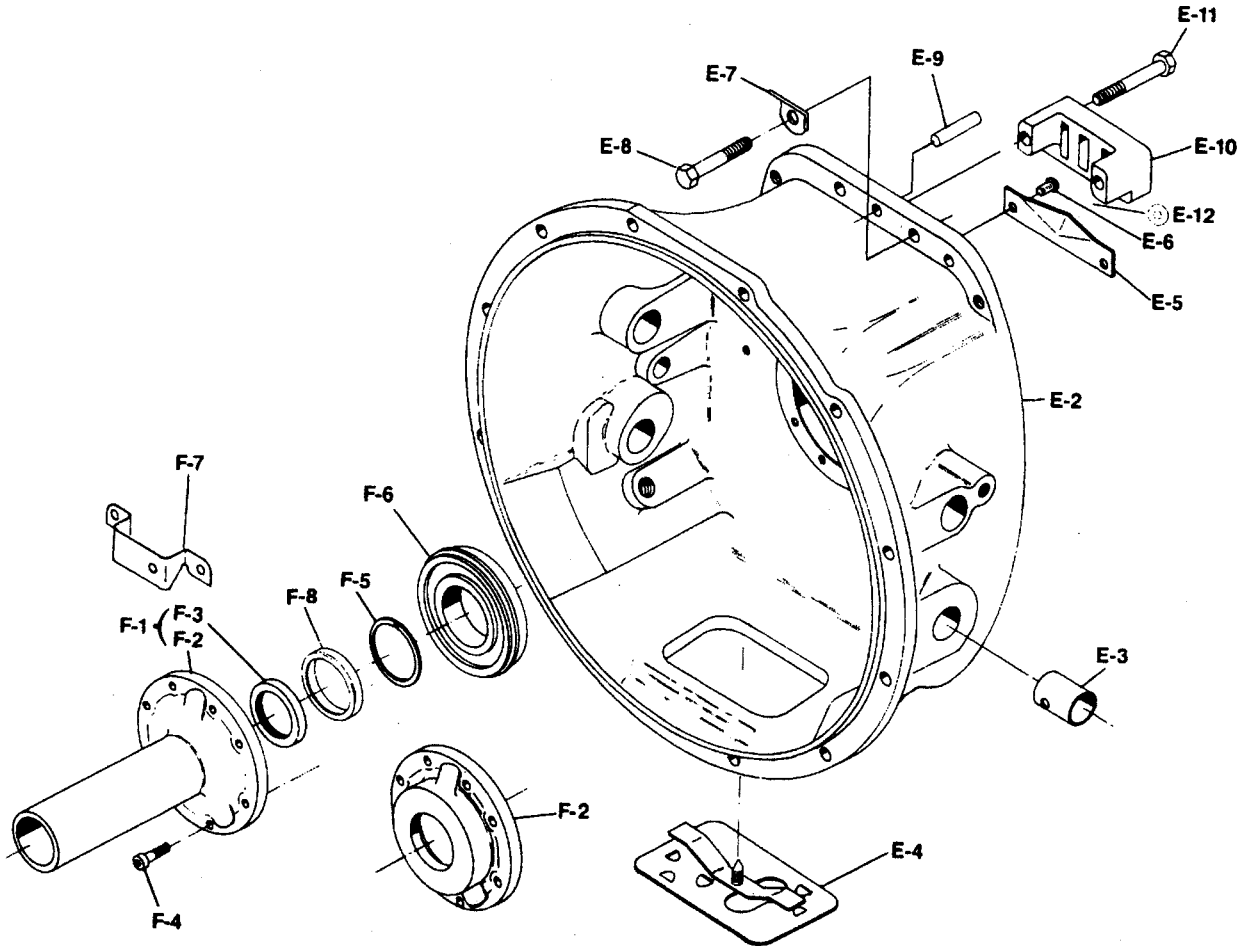

DRIVE GEAR BEARING CAP CHART

A Outside Diameter	B Stem Diameter	C Length	D Inside Dia. for Oil Seal	Drive Gear Front Bearing Cap		
				Casting Number	Brg. Cap Sub-Assembly Part Number	Includes Oil Seal F-3
FLAT TYPE - For Pull Type Clutches Pull Type Release						
5 1/8"	-	1.260"	2.562"	C40-19-27	49-19-10-1X	40-463-4-1X
STEM TYPE - For Push Type Clutches Pull Type Release						
5 1/8"	1.745"	4.134"	2 1/16"	C40-19-37	49-19-2-1X	40-463-6-1X
5 1/8"	1.871"	4.375"	2 1/16"	C40-19-37	49-19-4-1X	40-463-6-1X
5 1/8"	1.940"	6.260"	2 1/16"	C40-19-37	49-19-6-1X	40-463-6-1X
5 1/8"	1.871"	5.669"	2 1/16"	C40-19-37	49-19-7-1X	40-463-6-1X
5 1/8"	1.871"	6.654"	2 1/16"	C40-19-37	49-19-8-1X	40-463-6-1X
5 1/8"	1.871"	6.654"	2 1/16"	C40-19-37	49-19-9-1X	40-463-6-1X
5 1/8"	1.372"	5.360"	2 1/16"	C40-19-51	49-19-11-1X	40-463-6-1X

MODEL ES43-5

CLUTCH HOUSING and DRIVE GEAR BEARING CAP GROUP

T210-ES43-5

Ref. No.	Part No.	Description	Qty.
E-2	See Tab Bills	Clutch Housing	
	N.S.S.	Clutch Housing Assembly (see page 20)	1
E-3	128C-20	Clutch Housing (see dimension table below)	1
E-4	46-96-2-1X	Bushing - Clutch Release Shaft	2
E-5	40-468-1	Hand Hole Cover Assembly	1
E-6	545141	Oil Trough	1
		Pin - Drive Oil Trough	2
E-7	330564-1	Lift Hook	1
E-8	545002-4	Bolt - Clutch Housing to Case (.375-16 x 1.125)	16
E-9	545086	Dowel Pin - Case Front	2
E-10	40-477-1	Support - Front Shift Bar	1
E-11	545002-19	Bolt - Shift Bar Support (.375-16 x 2.25)	2
N.S.	500169-5	Nipple - Clutch Release Shaft	2
E-12	49-37-10	Spacer - Front Bar Support	2
F-1	See Tab Bills	Cap & Seal Assembly (see table page 6)	1
F-2	N.S.S.	Cap	1
F-3	40-463-6-1X	Seal - Drive Gear Bearing Cap (stem only)	1
or	40-463-4-1X	Seal - Drive Gear Bearing Cap (flat only)	1
F-4	545163	Cap Screw - Drive Gear Bearing Cap (.250-20 x 1.00 self-locking)	8
F-5	97-381-30	Snap Ring - Bearing Drive Gear Front	1
F-6	550988	Bearing - Drive Front	1
F-7	40-411-1	Return Spring Bracket (Navistar only)	1
F-8	49-468-2	Oil Ring	1

N.S.S. - Not Sold Separately

Size No.	SAE	
	A Pilot Diameter	B O.D.
1	20 1/8"	21 3/4"
2	17 5/8"	19 1/4"
3	16 1/8"	17 3/4"

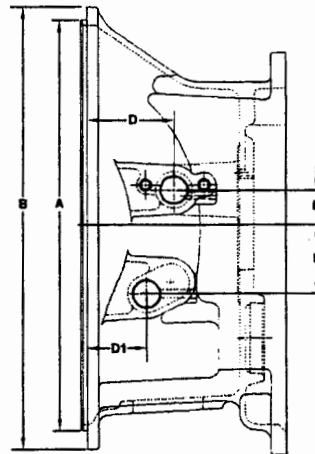

CLUTCH HOUSING				RELEASE SHAFT HOLE				
Assembly No.	Casting No.	S A E	C Length	Shaft Hole Dia.	D C/L to Front Face Upper Hole	E Above C/L Upper Hole	D1 C/L to Front Face Lower Hole	F Below C/L Lower Hole
E-2								
49-518-9-2X	C49-518-1	2	8 35/64"	1.00"	3 3/4"	1 1/2"	2 9/16"	3.00"
++49-518-10-2X	C49-518-1	2	8 35/64"	1.00"	3 3/4"	1 1/2"	3 19/32"	2.50"
++49-518-11-2X	C49-518-1	2	8 35/64"	1.00"	3 3/4"	1 1/2"	2 9/16"	3.00"

++ - Housings Have (2) Tapped Holes Either Side of the Shaft Hole.

MODEL ES43-5 CASE GROUP

T210-ES43-5

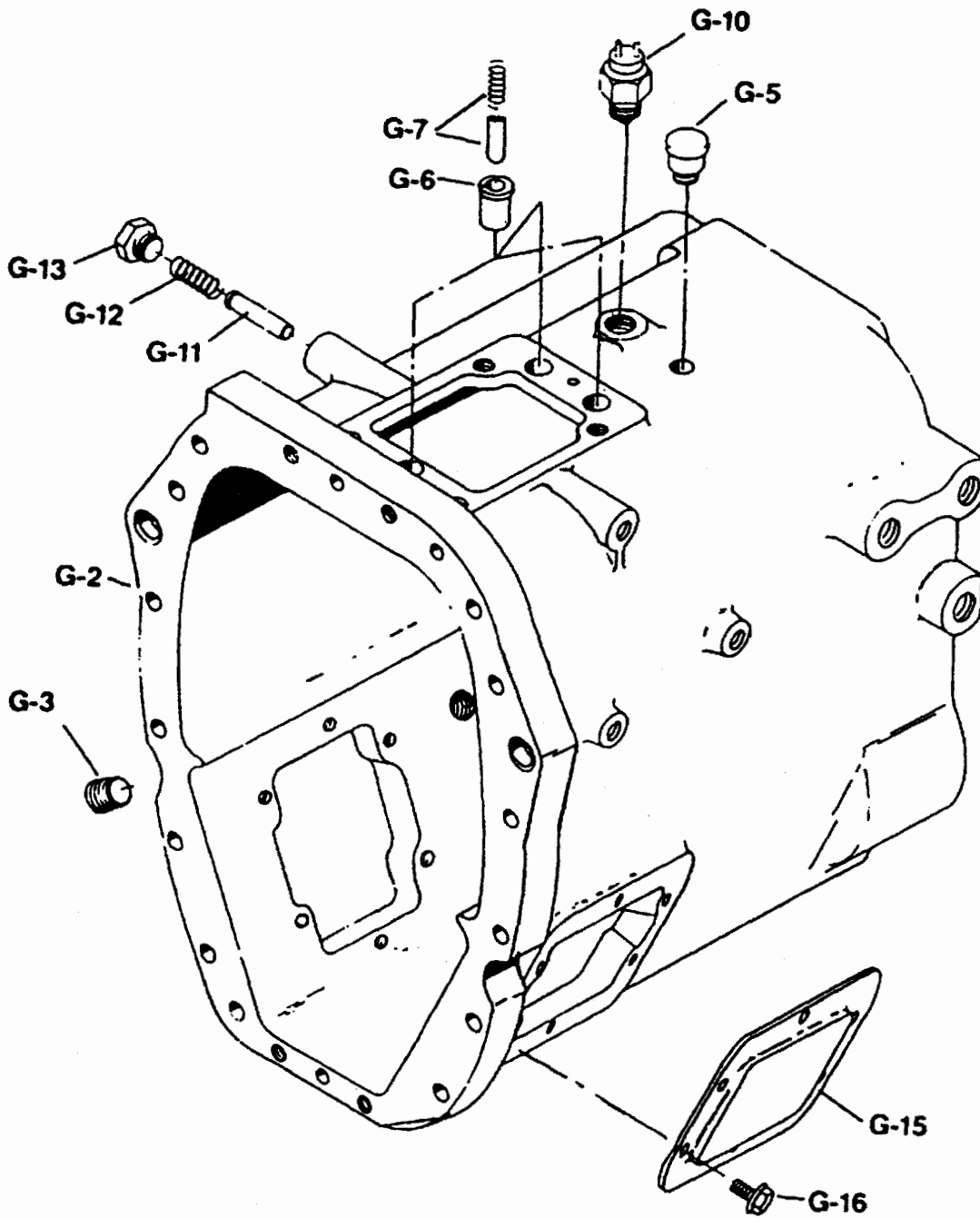

EASY SHIFT 5 SPEED MODELS (430 lb-ft) CASE GROUP and RELATED PARTS

T210-ES43-5

Ref. No.	Part No.	Description	Qty.
Case Group			
G-1	See Tab Bills	Case Assembly (includes G-1 thru G-6)	1
G-2	N.S.S.	Case (casting number C49-15-7)	1
N.S.	NP-96	Name Plate	1
N.S.	NP-196	Patent Plate	1
N.S.	252-SP	Pin - Name Plate	4
N.S.	330934	Magnet - Ceramic	1
N.S.	330800	Plug - Side Hole ($\frac{3}{8}$ " - 16 x $\frac{3}{4}$ ")	4
G-3	545123	Plug - Filler/Drain ($\frac{3}{4}$ " - 14 N.P.I.F.)	2
G-5	312268	Breather	1
G-6	40-487-1	Insert - Poppet Spring & Plunger	3
G-7	101-438-9-2X	Plunger Assy. (includes 3 springs and 3 poppets)	1
G-10	313538	Switch - Back-Up Light (Navistar only)	1
or	313539	Switch - Back-Up Light (Ford)	1
N.S.	40-263-2	Sleeve - Back-Up Light (shipping)	1
G-11	40-438-1	Pin - 1st & Reverse Select Plunger	1
G-12	62-72-8	Spring - 1st & Reverse Shift Finger Plunger	1
or	40-72-3	Spring - 1st & Reverse Shift Finger Plunger (white) (R.V.I.)	1
or	30-72-6	Spring - 1st & Reverse Shift Finger Plunger	1
G-13	545128	Plug - 1st & Reverse Plunger	1
G-15	50-267-2	Cover - PTO Aperture (6 bolt)	2
N.S.	545056-6	Anaerobic Sealant	A/R
G-16	330800	Screw - PTO Aperture Cover (.375-16 x .750)	12

*-Back-Tapered Clutching Teeth Version (After Serial No. J960601000)

** - Straight Clutching Teeth Version (Before Serial No. J960601000)

N.S.S. - Not Sold Separately

N.S. - Not Shown

A/R - As Required

◀◀◀◀ **IMPORTANT**

MODEL ES43-5

REAR BEARING CAP GROUP and RELATED PARTS

T210-ES43-5

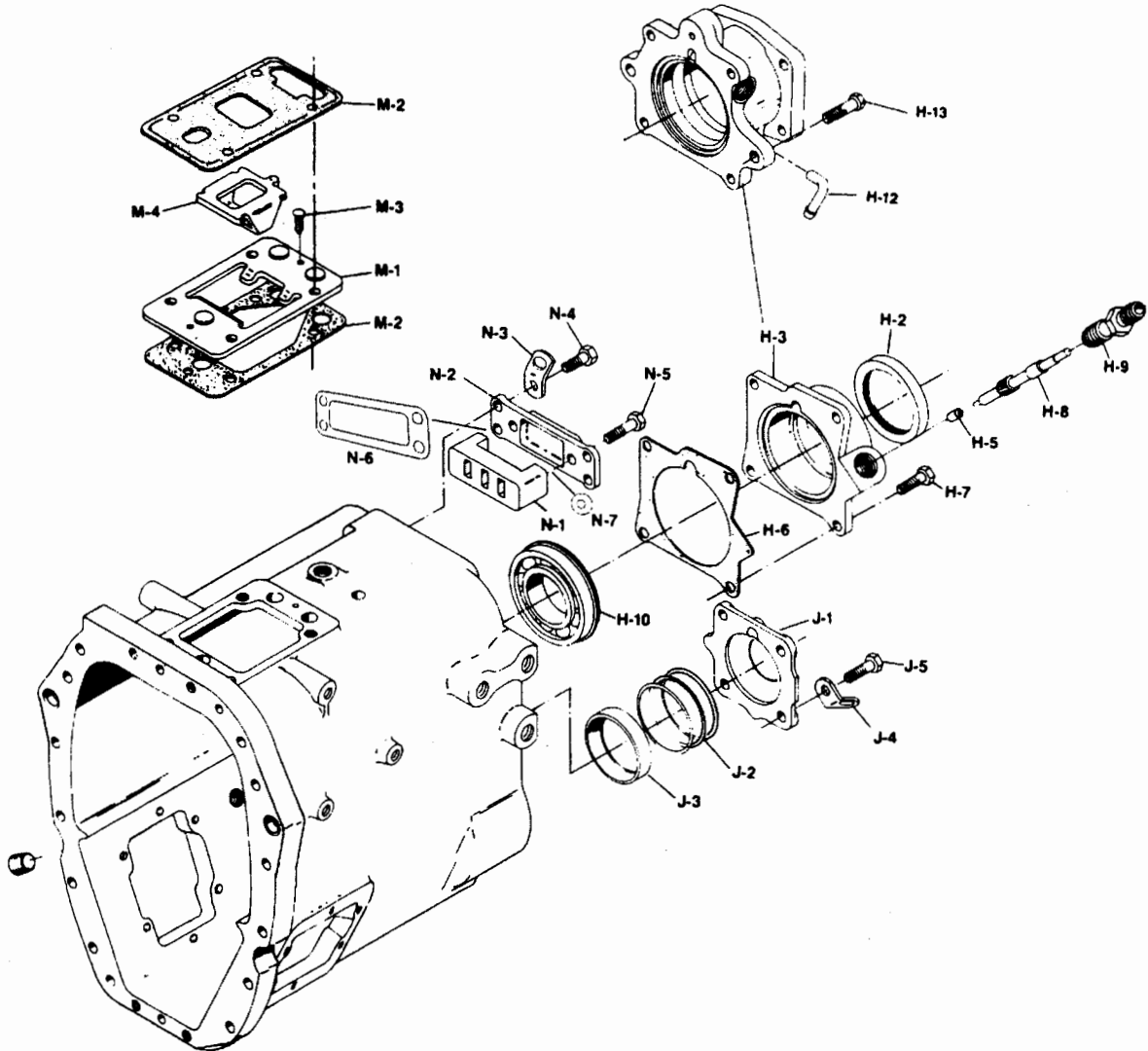

MAINSHAFT REAR BEARING CAP TABLE

Part Number	Part Number Includes				Type & Description	Used By
	Oil Seal H-2	Casting Number	Speedo Bush. H-5	Gasket H-6		
40-19-19-2X	63-463-1	C40-19-20	60-465-1	40-223-5	12x4 DCM, Mech. Speedo	Navistar
40-19-22-2X	63-463-1	C40-19-23	60-465-1	40-223-5	9x3/10x3 Bend. Mech. Speedo	All
40-19-38-2X	63-463-1	C40-19-46	60-465-1	40-223-4	Air Cap, Mech. Speedo	Ford & Std.
40-19-39-1X	63-463-1	C40-19-52	—	40-223-4	Air Cap, Elec/Mech Speedo	Nav. & GM
40-19-41-2X	63-463-1	C40-19-44	—	40-223-5	12x4 Elect. Speedo Only	Navistar
40-19-42-2X	63-463-1	C40-19-45	—	40-223-5	9x3 Elect. Speedo Only	Navistar
40-19-43-2X	63-463-1	C40-19-46	—	40-223-4	Air Cap, Elect. Speedo Only	Navistar
40-19-49-2X	63-463-1	C40-19-46	—	40-223-4	Air Cap, Elect. Speedo (Metric)	Volvo

MODEL ES43-5

REAR BEARING CAP GROUP and RELATED PARTS

T210-ES43-5

Ref. No.	Part No.	Description	Qty.
Mainshaft Rear Bearing Cap Group			
H-1	See Tab Bills	Cap Assembly - Mainshaft Bearing Rear	1
H-2	63-463-1	Oil Seal - Mainshaft Rear Bearing Cap	1
H-3	See Page 10	Cap Sub Assembly - Mainshaft Rear	1
H-4	N.S.S.	Cap - Mainshaft Rear Bearing	1
H-5	See Page 10	Bushing - Speedometer	1
H-6	40-223-4	Gasket - Mainshaft Rear Bearing Cap	1
or	40-223-5	Gasket - Mainshaft Rear Bearing Cap (brake only)	1
H-7	545002-4	Bolt - Rear Bearing Cap (.375-16 x 1.125)	4
H-8	See Tab Bills	Gear - Speedometer Drive	1
H-9	97-454-2-1X	Sleeve & Oil Seal	1
N.S.	44-539-1	Cap - Speedometer Dust	1
N.S.	55-334-1	Plug - Speedometer (used without driven gear)	1
N.S.	545106	Plug - Speedometer Outlet (electronic)	1
H-10	550989	Bearing - Mainshaft Rear	1
N.S.	545021	Plug - Electronic Speedometer (Ford)	1
H-12	37179	Tube - Vent (assembly to front of transmission)	1
H-13	545134	Bolt - Cap (D.C.M. brake)	2
or	545012	Plug - Case (rear holes)	2
Countershaft Rear Bearing Cap Group			
J-1	101-22-1	Cap - Countershaft Rear Bearing	1
J-2	49-228-1-1	Shim - Countershaft Rear Bearing (.0055/.0045)	1
or	49-228-1-2	Shim - Countershaft Rear Bearing (.0110/.0090)	1
or	49-228-1-3	Shim - Countershaft Rear Bearing (.0165/.0135)	1
J-3	550978	Cup - Countershaft Rear Bearing	1
J-4	330564-1	Lift Hook	1
J-5	545002	Bolt - Countershaft Rear Bearing Cap (.375-16 x 1.00)	4
Interlock Group			
M-1	40-200-1	Plate - Interlock Retainer	1
M-2	101-118-1	Gasket - Case to Interlock Plate (bottom)	1
and	101-118-2	Gasket - Case to Interlock Plate (top)	1
M-3	545091	Screw - Drive (interlock retainer)	2
M-4	40-200-2	Plate - Interlock	1
Rear Shaft Bar Support Group			
N-1	49-477-3	Support - Rear Shift Bar	1
N-2	40-96-1	Cap - Rear Shift Bar	1
N-3	330564-1	Lift - Hook	1
N-4	545002	Screw - Shift Bar Cap (.375-16 x 1.00)	4
N-5	545002-9	Screw - Shift Bar Support (.375-16 x 2.250)	2
N-6	49-223-1	Gasket - Shift Bar Cover	1
N-7	49-37-10	Spacer - Rear Bar Support	2

N.S.S. - Not Sold Separately
N.S. - Not Shown

MODEL ES43-5

REMOTE CONTROL ASSEMBLY

T210-ES43-5

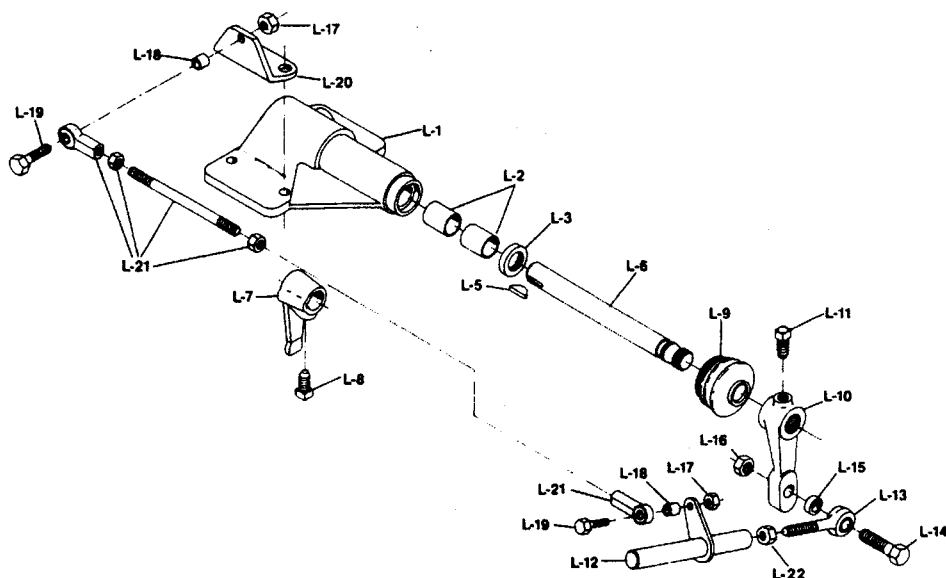

Ref. No.	Part No.	Description	40-18-1		
			-2X	-3X	-6X
	See Tab Bills	Remote Control Assembly	1	1	1
	40-18-1-1X	Remote Control Cover Assembly	1	1	1
L-1	N.S.S.	Remote Control Cover	1	1	1
L-2	40-24-1	Bushing - Remote Control Cover	2	2	2
L-3	28P-19	Seal - Remote Control Rod	1	1	1
N.S.	40-65-1-1X	Inner Shifter Shaft, Finger and Key	1	1	1
L-5	500007-19	Key - Shift Bracket	1	1	1
L-6	40-65-1	Shaft - Remote Control	1	1	1
L-7	40-6-1	Finger - Shift	1	1	1
L-8	545063	Set Screw - 7/8" - 20 x .72" Square Head	1	1	1
L-9	97-483-3	Boot - Shift Rod	1	1	1
N.S.	LW-3-9	Lockwire	2	2	2
L-10	40-6-3	Control Lever	1	-	1
or	40-6-5	Control Lever	-	1	-
L-11	545136	Set Screw - 7/16" - 14 x 7/8 Square Head	1	1	1
L-12	40-65-3-1X	Shift Rod	1	1	-
L-13	330938	Rod End (1/2" 20UNF)	1	1	-
L-14	545001-2	Bolt - Control Lever (1/2" - 13 x 2 1/4" hex head)	1	1	-
L-15	40-38-2	Spacer - Control Lever Bolt	1	1	-
L-16	500370-5	Nut - Control Lever and Rod End (1/2" - 13 hex)	1	1	-
L-17	500370-3	Nut - Tie Rod Assembly Mounting Bolt (3/8" - 16 hex)	2	2	-
L-18	40-38-3	Spacer - Tie Rod Assembly Mounting Bolt	2	2	-
L-19	545002-5	Bolt - Tie Rod Assembly (3/8" - 16 x 1.75 hex hed)	2	2	-
L-20	40-354-3	Bracket - Tie Rod	1	1	-
L-21	40-65-2-1X	Tie Rod Assembly	1	1	-
L-22	500371-5	NUT - Control Shift Rod	1	1	1

N.S.S. - Not Sold Separately

N.S. - Not Shown

MODEL ES43-5

COMPANION FLANGES and END YOKES

T210-ES43-5

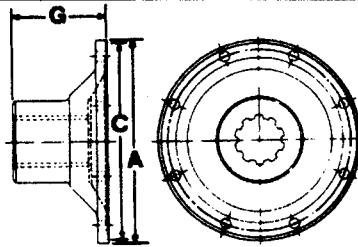

COMPANION FLANGE

Companion Flanges

Joint Series	A Flange Diameter	Part No. Companion Flange Assembly	Part No. Companion Flange	G End of Hub to Flange Face Length	C Pilot Diameter F-Female M-Male	Brake Size
1480/1550	Rectangular	—	53-106-2	2 7/8"	F-3 3/4"	9 x 3 or 12 x 4

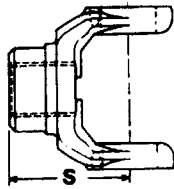

FULL ROUND

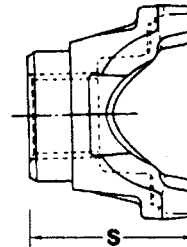

U-BOLT—BRG. STRAP—HALF ROUND

Series	Yoke Style	End Yoke Part Number	S End of Hub to Center Line Length	Joint Angle	Brake Size
1480	U-Bolt	3-4-8781	4 11/64"	22 1/2°	—
1480	Brg. Strap**	3-4-8931-2	3 29/32"	23 1/2°	—
1550	U-Bolt	4-4-4491	4 1/64"	21 1/2°	—
1550	Brg. Strap*	4-4-4491-1	4 1/64"	21 1/2°	—
1550	Brg. Strap**	4-4-4491-2	4 1/64"	21 1/2°	—
1550	U-Bolt	4-4-4601	6 27/64"	22°	12 x 4
1550	U-Bolt	4-4-4611	4 11/64"	22 1/2°	—
1550	Brg. Strap*	4-4-4611-1	4 11/64"	22 1/2°	—
1550	Brg. Strap**	4-4-4611-2	4 11/64"	22 1/2°	—
1550	Half Rnd.	(A) 4-4-6111-1X	7 9/32"	22°	12 x 4
1610	Full Rnd.	5-4-6321	4"	19°	—
1610	Half Rnd.	5-4-6321-1	4"	19°	—
1610	Full Rnd.	5-4-6481	4 11/64"	22 1/2°	—
1610	Half Rnd.	5-4-6481-1	4 11/64"	22 1/2°	—
1610	Full Rnd.	5-4-6491	6 21/32"	22°	12 x 4
1610	Half Rnd.	(A) 5-4-7611-1X	7 9/16"	22°	12 x 4
1710	Full Rnd.	6-4-7301	5 1/4"	33 1/2°	—
1710	Half Rnd.	6-4-7301-1	5 1/4"	33 1/2°	—

(A) Assembly Includes Brake Drum

*With Tapped Holes

**With Thru Holes

EASY SHIFT 5 SPEED MODELS (430 lb-ft)

SHIFT BAR and FORK ASSEMBLY

T210-ES43-5

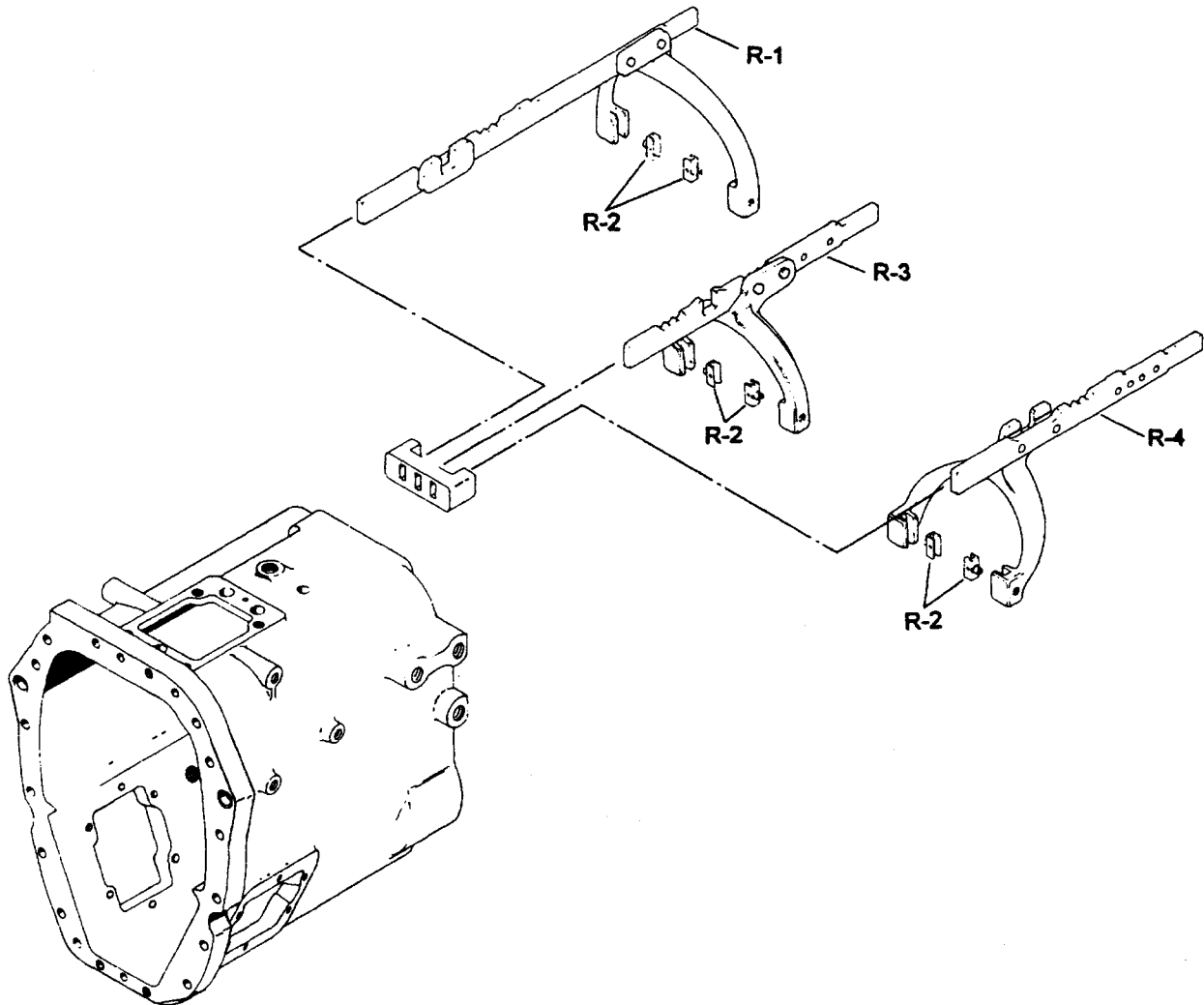

Ref. No.	Part No.	Description	Qty.
		Shift Bar and Fork Assembly	
R-1	313723-1X	Fork and Bar Assembly - 1st and Reverse (includes R-2, 1 poppet plunger, and 1 spring)	1
R-2	101-486-1-1X	Kit - Shift Fork Clip (includes (2) clips) (included in R-1, R-3, and R-4)	3
R-3	49-69-2-1X	Fork and Bar Assembly - 2nd and 3rd* (includes R-2, 1 poppet plunger, and 1 spring)	1
or	313760-1X	Fork and Bar Assembly - 2nd and 3rd** (includes R-2, 1 poppet plunger, and 1 spring)	1
R-4	49-69-1-1X	Fork and Bar Assembly - 4th and 5th* (includes R-2, 1 poppet plunger, and 1 spring)	1
or	313761-1X	Fork and Bar Assembly - 4th and 5th** (includes R-2, 1 poppet plunger, and 1 spring)	1

*-Back-Tapered Clutching Teeth Version (After Serial No. J960601000)

** - Straight Clutching Teeth Version (Before Serial No. J960601000)

◀◀◀◀ ◀◀◀◀ ◀◀◀◀ ◀◀◀◀ **IMPORTANT**

MODEL ES43-5

SHIFT LEVER and DOME ASSEMBLY

T210-ES43-5

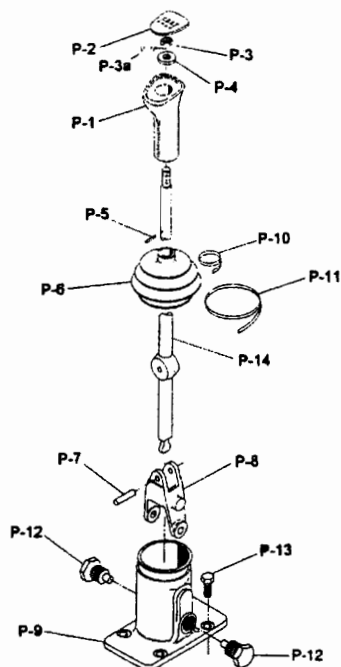

Ref. No.	Part No.	Description	101-17-2	
			-28X	-29X
	313768-2X	Sub-Assy. - Shift Knob (includes P-1 thru P-5)	1	1
P-1	39Q-35	Handle - Shift Lever	1	1
P-2	49-20-1	Insert - Shift Lever Handle (ES43-5 & ES53-5)	1	1
P-2	101-20-9	Insert - Shift Lever Handle (ES52-7 & ES066-7B)	1	1
P-3	500370-5	Nut - Shift Knob Retaining	1	1
P-3a	500357-13	Washer - Shift Lever Retaining (lock type)	1	1
P-4	201-451-2	Washer - Shift Knob	1	1
P-5	201-438-8	Pin - Shift Knob	1	1
N.S.	101-17-2-10X	Sub Assy. - Shift Tower (includes P-6 thru P-13)	1	1
P-6	101-483-2	Boot - Shift Tower and Lever	1	1
P-7	53Q-20	Pin - Pivot (Gimbal)	1	1
P-8	48Q-60	Yoke - Shift (Gimbal)	1	1
P-9	101-17-2	Tower - Shift (Gimbal)	1	1
P-10	33Q-15-1	Tie Cable - Upper	1	1
P-11	33Q-15-2	Tie Cable - Lower	1	1
P-12	313591X	Kit - Trunion Screws (includes (2) Trunion screws) 545135	1	1
P-13	545028	Screw - Shift Tower	4	4
P-14	25Q-2594-10	Shift Lever (26.400" long) Straight	1	-
	25Q-2594-11	Shift Lever (30.712" long) Straight	-	1
	2851	Bulletin — Installation Shift Knob	1	1
		Parts Not Included In Tower Assemblies		
N.S.	201-483-4	Boot - Floorboard (oval)		
N.S.	201-483-5	Boot - Floorboard (rectangular)		
N.S.	101-483-13	Boot - Internal (UPS)	1	1

N.S. - Not Shown

N.S.S. - Not Sold Separately

MODEL ES43-5

CLUTCH RELEASE CODE TABLE

T210-ES43-5

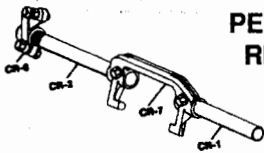

**PEDAL ADJUSTING ARM
RIGHT SIDE—310473X**

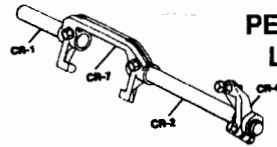

**PEDAL ADJUSTING ARM
LEFT SIDE—310233X**

CR-1 SHORT SHAFT

Part No.	Length
106C-1142	6.125"
106C-1185	5.750"
106C-1216	4.750"
106C-1278	4.812"
106C-1360	5.312"
106C-1375	6.781"
106C-1498	6.500"
330601-1	6.250"

CR-1 LONG SHAFT (Cont'd)

Part No.	Type	Length
106C-1083	RS-8	7.969"
106C-1094	RS-8	8.469"
106C-1123	RS-8	12.968"
106C-1315	RS-8	7.625"
106C-1367	RS-8	10.312"
106C-1375	RS-8	6.781"
106C-1417	RS-8	7.250"
106C-1422	RS-8	7.500"
106C-1490	RS-8	16.000"
106C-1515	RS-5	11.375"
106C-1529	RS-5	8.312"
330610-5	RS-8	9.469"
46-510-9	RS-5	7.125"
330610-10	RS-8	9.500"

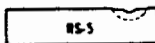

CR-2 LONG SHAFT

Part No.	Type	Length
106C-438	RS-5	14.000"
106C-617	RS-8	10.469"
106C-839	RS-8	11.469"
106C-939	RS-8	10.000"
106C-953	RS-8	9.750"
106C-959	RS-8	11.968"
106C-960	RS-8	8.719"
106C-1046	RS-8	8.968"
106C-1047	RS-8	9.469"

CR-6 PEDAL ADJ. ARM

310233X	For Left Side Mtg.
310473X	For Right Side Mtg.
47-526-1-1X*	Lever Type 7 1/4"
310873X*	Lever Type 7 1/4"

*Lever type can be used on either right or left side.

THRU SHAFT (used with push type clutch)

Part No.	Type	Length
106C-1566	Splined	19.125"
106C-1578	Splined	19.500"
49-510-1	Keyed	19.120"
97-510-2	Splined	19.313"

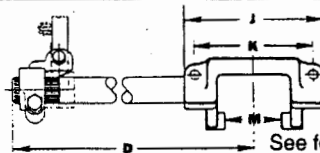

See following page for "D" dimensions.

CLUTCH RELEASE YOKES

CR-7	Forging No.	Used With	Type	J	K	M
105C-64	F105C64	Spicer 15 1/2" SP	Pull	8.000"	6.500"	4.895"
105C-68	F105C99	Spicer 14" SP	Pull	7.125"	5.750"	4.132"
105C-117 ¹	F105C118	Spicer & Others	Push	8.375"	7.000"	4.885"
105C-124 ²	F105C125	Spicer AL & AR	Push	3.750"	2.125"	2.885"
105C-132 ²	F105C118	Spicer & Others	Push	8.375"	7.000"	4.885"
105C-137	F105C138	Spicer 13" and	Pull	8.000"	6.500"	4.895"
	C105C138	14" 2P				
85-509-3 ³	F105C118	Spicer & Others	Push	8.375"	7.000"	4.885"

¹Machined washer surface on yoke front

²Machined washer surface on yoke rear (for clearance)

³Same as ¹ above except contains spring holes in lugs

■ Use 7743X Clutch Release Bearing and (2) 230C-12 Springs

★ CLUTCH RELEASE YOKE ATTACHING PARTS—

Use one KEY 10-30, two SCREWS 330231 and two LOCK WASHERS 500356-12

NOTE: When changing from a two plate to single plate clutch or vice versa, a different bearing cap will be required.

MODEL ES43-5

CLUTCH RELEASE CODE TABLE

T210-ES43-5

Rel.Code See Tab Bill	CR-7 Yoke★	Shaft		Adjustable Arm	D Dim. (In.)	Rel. Code See Tab Bill	CR-7 Yoke★	Shaft		Adjustable Arm	D Dim. (In.)
		CR-1 Short	CR-2 Long					CR-1 Short	CR-2 Long		
1	105C-64	106C-1142	106C-1047	310233X	11.969	61	105C-137	106C-1185	106C-839	310233X	13.969
2	105C-64	106C-1185	106C-438	—	16.500	62	105C-137	106C-1185	106C-939	310233X	12.500
3	105C-64	106C-1185	106C-939	310233X	12.500	63	105C-137	106C-1185	106C-939	310473X	12.500
4	105C-64	106C-1185	106C-1046	310233X	11.468	64	105C-137	106C-1185	106C-953	310473X	12.250
5	105C-64	106C-1185	106C-1047	310233X	11.969	65	105C-137	106C-1185	106C-1046	310233X	11.468
6	105C-64	106C-1185	106C-1047	47-526-1-1X	11.969	66	105C-137	106C-1185	106C-1046	310473X	11.468
7	105C-64	106C-1544	106C-839	310233X	13.969	67	105C-137	106C-1185	106C-1047	310233X	11.969
8	105C-68	106C-1142	106C-438	—	16.125	68	105C-137	106C-1185	106C-1083	310233X	10.469
9	105C-68	106C-1142	106C-617	—	12.594	69	105C-137	106C-1185	106C-1094	—	10.969
10	105C-68	106C-1142	106C-617	310233X	12.594	70	105C-137	106C-1185	106C-1094	310233X	10.969
11	105C-68	106C-1142	106C-839	310233X	13.594	71	105C-137	106C-1185	106C-1123	—	15.468
12	105C-68	106C-1142	106C-939	310233X	12.125	72	105C-137	106C-1185	106C-1123	310233X	15.468
13	105C-68	106C-1142	106C-1046	310233X	11.093	73	105C-137	106C-1185	106C-1367	—	12.812
14	105C-68	106C-1142	106C-1047	310233X	11.594	74	105C-137	106C-1185	106C-1367	310233X	12.812
15	105C-68	106C-1278	106C-438	—	16.125	75	105C-137	106C-1185	106C-1375	310873X	9.281
15A	105C-68	106C-1278	106C-939	310473X	12.125	76	105C-137	106C-1185	106C-1515	—	13.875
15B	105C-68	106C-1278	106C-939	310233X	12.125	77	105C-137	106C-1185	106C-1529	—	10.812
18	105C-117	106C-1142	106C-939	310233X	12.750	78	105C-137	106C-1185	330610-5	—	11.969
19	105C-117	106C-1185	106C-438	—	16.750	78A	105C-137	106C-1185	46-510-9	—	9.625
20	105C-117	106C-1185	106C-617	310233X	13.219	79	105C-137	106C-1216	106C-617	310233X	12.969
21	105C-117	106C-1185	106C-839	47-526-1-1X	14.219	80	105C-137	106C-1278	106C-438	—	16.500
22	105C-117	106C-1185	106C-939	310233X	12.750	83	105C-137	106C-1278	106C-617	310233X	12.969
23	105C-117	106C-1185	106C-953	310873X	12.500	84	105C-137	106C-1278	106C-939	310233X	12.500
24	105C-117	106C-1185	106C-960	310233X	11.469	84A	105C-137	106C-1278	106C-939	310473X	12.500
25	105C-117	106C-1185	106C-1046	310233X	11.718	85	105C-137	106C-1278	106C-939	310873X	12.500
26	105C-117	106C-1185	106C-1047	310233X	12.219	86	105C-137	106C-1278	106C-960	310233X	11.219
27	105C-117	106C-1185	106C-1083	—	10.719	87	105C-137	106C-1278	106C-1046	—	11.468
28	105C-117	106C-1185	106C-1083	310233X	10.719	88	105C-137	106C-1278	106C-1046	310233X	11.468
29	105C-117	106C-1185	106C-1083	310473X	10.719	89	105C-137	106C-1278	106C-1047	—	11.969
30	105C-117	106C-1185	106C-1094	310233X	11.219	90	105C-137	106C-1278	106C-1047	310233X	11.969
31	105C-117	106C-1185	106C-1094	310873X	11.219	91	105C-137	106C-1278	106C-1083	310233X	10.469
32	105C-117	106C-1185	106C-1169	310233X	11.875	91A	105C-137	106C-1278	106C-1083	310473X	10.469
33	105C-117	106C-1185	106C-1315	—	10.375	92	105C-137	106C-1278	106C-1094	310233X	10.969
34	105C-117	106C-1185	106C-1315	310233X	10.375	92A	105C-137	106C-1278	106C-1315	310233X	10.125
35	105C-117	106C-1185	106C-1315	47-526-1-1X	10.375	93	105C-137	106C-1278	106C-1375	310233X	9.281
35A	105C-117	106C-1185	106C-1375	310873X	9.531	94	105C-137	106C-1278	106C-1422	310233X	10.000
36	105C-117	106C-1185	106C-1417	310233X	10.000	95	105C-137	106C-1278	106C-1529	—	10.812
37	105C-117	106C-1185	106C-1417	310873X	10.000	96	105C-137	106C-1360	106C-1083	—	10.469
38	105C-117	106C-1185	106C-1490	310233X	18.750	96A	105C-137	106C-1360	106C-1417	310233X	9.750
39	105C-117	106C-1278	106C-939	310233X	12.750	97	105C-137	106C-1360	106C-1422	310233X	10.000
40	105C-117	106C-1278	106C-960	310873X	11.469	98	105C-137	106C-1375	106C-438	310233X	16.500
41	105C-117	106C-1278	106C-1047	310233X	12.219	99	105C-137	106C-1498	106C-438	—	16.500
42	105C-117	106C-1278	106C-1094	310233X	11.219	100	105C-137	106C-1498	106C-617	310233X	12.969
43	105C-117	106C-1278	106C-1315	310233X	10.375	101	105C-137	106C-1498	106C-617	310473X	12.969
44	105C-117	106C-1278	106C-1367	310233X	13.062	102	105C-137	106C-1498	106C-939	310233X	12.500
45	105C-117	106C-1360	106C-1083	310233X	10.719	103	105C-137	106C-1498	106C-939	310473X	12.500
46	105C-117	106C-1360	106C-1315	310233X	10.375	104	105C-137	106C-1498	106C-953	310233X	12.250
46A	105C-117	106C-1360	330610-10	—	12.250	105	105C-137	106C-1498	106C-959	310233X	14.468
49	105C-124■	106C-1185	106C-438	—	14.313	106	105C-137	106C-1498	106C-1046	310233X	11.468
50	105C-124■	Thru Shaft	106C-1566	310233X	—	107	105C-137	106C-1498	106C-1047	—	11.969
51	105C-124■	Thru Shaft	106C-1566	310473X	—	108	105C-137	106C-1498	106C-1047	310233X	11.969
52	105C-124■	Thru Shaft	106C-1566	310873X	—	109	105C-137	106C-1498	106C-1083	310233X	10.469
52A	105C-124■	Thru Shaft	49-510-1	310233X	—	110	105C-137	106C-1498	106C-1094	—	10.969
53	105C-132	106C-1185	106C-1047	310233X	9.782	112	105C-137	330601-1	106C-939	310233X	12.500
54	105C-132	106C-1185	106C-1083	310233X	8.282	112A	85-509-3	106C-1278	106C-939	310233X	12.750
55	105C-132	106C-1185	106C-1417	310873X	7.563	113	85-509-3	106C-1360	106C-1417	310233X	10.000
56	105C-132	106C-1185	49-510-9	—	7.438	114	85-509-3	Thru Shaft	106C-1578	310233X	—
57	105C-132	106C-1278	46-510-9	—	7.438	114A	85-509-3	Thru Shaft	106C-1578	310473X	—
59	105C-137	106C-1185	106C-438	—	16.500	115	85-509-3	Thru Shaft	106C-1578	310873X	—
60	105C-137	106C-1185	106C-617	310233X	12.969	116	312916	Thru Shaft	97-510-2	—	—

■ Use 7743X Clutch Release Bearing and (2) 230C-12 Springs

MODEL ES43-5 OVERHAUL KITS

T210-ES43-5

Part No.	Description	Qty.
	Major Overhaul Kit	
49-400-2X	Major Overhaul Kit	1
501200	Nut - Mainshaft Output	1
53-205-1	Washer - Mainshaft Nut	1
313401-34X	Thrust Washer Kit	1
313429-26X	Shifter Housing Small Parts Kit	1
313432-46X	Minor Overhaul Kit	1
	Minor Overhaul Kit (included in major overhaul kit)	
313432-46X	Minor Overhaul Kit	1
	Bearings	
550986	Mainshaft Pocket	1
550989	Mainshaft Rear Cone	1
550988	Drive Gear Front	1
550963	Mainshaft 2nd & Reverse	2
550886	Reverse Idler Gear	2
550964	Countershaft Front - Cone	2
550965	Countershaft Front - Cup	1
550868	Countershaft Rear - Cone	1
550978	Countershaft Rear - Cup	1
550968	Mainshaft 3rd Needle	1
550991	Mainshaft 1st Speed	1
550990	Mainshaft 4th Speed	1
101-486-1	Clip - Shift Fork	6
40-463-4-1X	Seal - Drive Gear (flat type)	1
40-463-6-1X	Seal - Drive Gear (stem type)	1
63-463-1	Seal - Mainshaft Rear	1
545077	#2 Moly Grease (packet)	1
545080-1	Loctite - Threadlock Adhesive (vial)	1
312475-47X	Gasket Kit	1
313438-3X	Shim Kit - Countershaft Rear	1
313024-17X	Snap Ring - Kit	1
	Service Manual	1
2770	Bulletin - Bearing Lube Instruction	1
2783	Bulletin - Loctite Application for Mainshaft Nut	1
	Thrust Washer Kit (included in major overhaul kit)	
313401-34X	Thrust Washer Kit (included in major overhaul kit)	1
49-47-2	Mainshaft - 3rd & 4th Speed	1
49-47-1	Mainshaft - 1st & 2nd Speed	1
101-47-4	Mainshaft - Reverse	1
545087	Pin - Lock	2
	Shifter Housing Small Parts (included in major overhaul kit)	
313429-26X	Shifter Housing Small Parts (included in major overhaul kit)	1
2823	Bulletin - Shift Bar Assembly & Poppet Plunger	1
101-438-9	Plunger - Poppet	3
40-487-1	Insert - Poppet Spring and Ball	3
40-438-1	Pin - 1st and Reverse Select Plunger	1
101-72-7	Spring - Shift Bar Poppet	3
30-72-6	Spring - 1st & Reverse Shift Finger Plunger	1

MODEL ES43-5 OVERHAUL KITS

T210-ES43-5

Part No.	Description	Qty.
312475-47X	Gasket Kit (included in minor overhaul kit)	1
40-223-4	Mainshaft Rear Bearing Cap	1
40-223-5	Mainshaft Rear Bearing Cap (D.C.M. brake)	1
101-118-1	Tower	1
101-118-2	Tower	1
545056-10	Anaerobic Sealant	1
49-223-1	Gasket - Shift Bar Cover	1
2792	Bulletin - Liquid Gasket	1
313024-17X	Snap Ring Kit (included in minor overhaul kit)	1
40-381-3	Mainshaft 3rd & 4th Thrust Washer	1
40-381-3	Countershaft Head End Gear	1
40-381-4	Mainshaft 2nd & 3rd Clutch Gear	1
49-381-1	Mainshaft 1st & 2nd Speed Thrust Washer	1
27-381-5	Countershaft 4th Gear	1
97 -381-30	Mainshaft Front Bearing	1
40-381-1	4th & 5th Gear	1
313438-3X	Shim Kit (included in minor overhaul kit)	1
49-228-1-3	Countershaft Rear Bearing Cap (.0165/.0135)	1
49-228-1-2	Countershaft Rear Bearing Cap (.0110/.0090)	1
49-228-1-1	Countershaft Rear Bearing Cap (.055/.0045)	1
2793	Bulletin - Countershaft Shim Kit	1
	Breakdown of Oil Seals in the Minor Overhaul Kit	
40-463-4-1X	Sub Assembly - Oil Seal & Installation Sleeve (flat cap)	1
40-463-4	Seal - Drive Gear Bearing Cap	1
40-204-1	Sleeve - Oil Seal Installation (1.75 diameter shaft)	1
40-204-2	Sleeve - Oil Seal Installation (1.50 diameter shaft)	1
2819	Bulletin - Oil Seal Installation Instruction	1
40-463-6-1X	Sub Assembly - Oil Seal & Installation Sleeve (stem cap)	1
40-463-6	Seal - Drive Gear Bearing Cap	1
40-204-2	Sleeve - Oil Seal Installation (1.500 diameter shaft)	1
40-204-3	Sleeve - Oil Seal Installation (1.375 diameter shaft)	1
2819	Bulletin - Oil Seal Installation	1

THE ANAEROBIC SEALANT SHOULD BE APPLIED AS FOLLOWS:

Approx. (4)cc for C/S Bearing Caps
 Approx. (4)cc for Rear Shift Bar Support
 Approx. (6)cc for Drive Gear Bearing Cap

A 50cc tube is supplied in the Minor Overhaul Kit

MODEL ES43-5

TABULATED BILLS OF MATERIAL

T210-ES43-5

Tab No.	Used By	For Use With Clutch	CLUTCH HOUSING			Main Drive Gear	Drive Gear Bearing Cap F-1	Case Assembly G-1
			S A E	Assembly No. E-1	Rel. Code Pages			
Model ES43-5A								
301633								
-1	Never Released	-	-	-	-	-	-	-
-2	Navistar	Push Type	2	49-518-9-1X	-	49-35-17-1X	49-19-9-1X	49-15-6-1X
-3	Navistar	Push Type	2	49-518-9-1X	-	49-35-17-1X	49-19-9-1X	49-15-6-1X
-4	Navistar	Push Type	2	49-518-9-1X	-	49-35-17-1X	49-19-9-1X	49-15-6-1X
-5	Navistar	Push Type	2	49-518-9-1X	-	49-35-17-1X	49-19-9-1X	49-15-6-1X
-6	Canadian Foremost	Push Type	3	46-518-21-1X	35	49-35-17-1X	49-19-9-1X	49-15-9-1X
-7	GMC - (UPS)	Push Type	-	49-360-5-1X**	-	49-35-22-1X	49-19-11-1X	49-15-6-1X
-8	Mercedes Benz	Push Type	2	49-518-10-1X	51	49-35-17-1X	49-19-6-1X	49-15-6-1X
-9	Mercedes Benz	Push Type	2	49-518-10-1X	51	49-35-17-1X	49-19-6-1X	49-15-6-1X
-10	Hino Motors	Push Type	2	49-518-10-1X	51	49-35-17-1X	49-19-8-1X	49-15-6-1X
-11	Cummins	Push	3	46-518-21-1X		49-35-17-1X	49-19-8-1X	49-15-8-1X
-12	DPD Aust	Push	3	46-518-21-18	50	49-35-17-1X	49-19-8-1X	49-15-8-1X
-13	OshKosh	Push	2	49-518-11-1X		49-35-17-1X	49-19-8-1X	49-15-6-1X
-14	TSP Dina	Pull	2	49-518-9-1X		49-35-17-1X	49-19-9-1X	49-15-6-1X
-15	TSP Dina	Pull	2	49-518-9-1X		49-35-17-1X	49-19-9-1X	49-15-6-1X
-16	TSP MBM	Pull	2	49-518-9-1X		49-35-20-1X	49-19-13-1X	49-15-11-1X
-17	Navistar	Push	2	49-518-9-1X		49-35-17-1X	49-19-9-1X	49-15-6-1X
-18	Navistar	Push	2	49-518-9-1X		49-35-23-1X	49-19-9-1X	49-15-6-1X
-19	Navistar	Push	2	49-518-9-1X		49-35-23-1X	49-19-9-1X	49-15-6-1X
-20	Navistar	Push	2	49-518-9-1X		49-35-23-1X	49-19-9-1X	49-15-6-1X
-21	OshKosh	Push	2	49-518-11-1X		49-35-17-1X	49-19-8-1X	49-15-6-1X
-22	Ford	Push	-	49-360-5-1X		49-35-16-1X	49-19-2-1X	49-15-8-1X
-23	TSP	Push	2	49-518-9-1X		49-35-17-1X	49-19-9-1X	49-15-6-1X
-24	General Motors	Push	-	49-360-5-1X		49-35-19-1X	49-19-4-1X	49-15-9-1X
-25	Navistar	Push	2	49-518-9-1X		49-35-17-1X	49-19-9-1X	49-15-6-1X
-26	Navistar	Push	2	49-518-9-1X		49-35-23-1X	49-19-9-1X	49-15-6-1X
-27	Navistar	Push	2	49-518-9-1X		49-35-23-1X	49-19-9-1X	49-15-6-1X
-28	GMC UPS	Push	-	49-360-5-1X		49-35-22-1X	49-19-11-1X	49-15-9-1X
-29	GMC UPS	Push	-	49-360-5-1X		49-35-22-1X	49-19-11-1X	49-15-9-1X
-30	Navistar	Push	2	49-518-9-1X		49-35-17-1X	49-19-9-1X	49-15-6-1X
-31	Ford	Push	2	49-518-10-1X		49-35-17-1X	49-19-6-1X	49-15-8-1X
-32	Never Released	-	-	-	-	-	-	-
-33	Franklin	Push	3	46-518-21-1X		49-35-17-1X	49-19-6-1X	49-15-8-1X
-34	Terra Flex	Push	3	46-518-21-1X		49-35-17-1X	49-198-1X	49-15-8-1X
-35	TSP	Pull	2	49-518-9-1X		49-35-21-1X	49-19-10-1X	49-15-6-1X
-36	OshKosh	Push	2	49-518-11-1X		49-35-17-1X	49-19-8-1X	49-15-6-1X
-37	Ted-Trans.	Push	3	46-518-21-1X		49-35-17-1X	49-19-8-1X	49-15-8-1X
-38	OshKosh	Push	2	49-518-10-1X		49-35-17-1X	49-19-14-1X	49-15-6-1X
-39	J.L.G.	Push	2	49-518-10-1X		49-35-17-1X	49-19-8-1X	49-15-6-1X
-40	HICO	Push	3	46-518-21-1X		49-35-17-1X	49-19-8-1X	49-15-9-1X
-41	Freightliner	Push	2	49-518-10-1X		49-35-17-1X	49-19-14-1X	49-15-6-1X
-42	TSP	Push	-	49-360-5-1X		49-35-22-1X	49-19-11-1X	49-15-9-1X
-43	American Transport	Push	2	49-518-9-1X		49-35-23-1X	49-19-9-1X	49-15-6-1X
-44	Rolligon Corp.	Push	3	49-360-5-1X		49-35-17-1X	49-19-6-1X	49-15-8-1X

MODEL ES43-5

TABULATED BILLS OF MATERIAL

T210-ES43-5

Tab No.	Mainshaft Rear Brg. Cap Assembly H-1	Speedometer		End Yoke or Companion Flange	Shifter		
		Drive Gear or Signal Gear B-24	Driven Gear H-7		Housing Assembly	Lever & Dome Assembly Pages	Remote Control Pages
Model ES43-5A							
301633							
-1	-	-	-	-	-	-	-
-2	40-19-42-2X	53-452-5	-	-	-	-	-
-3	40-19-43-2X	53-452-5	-	-	-	-	-
-4	40-19-42-2X	53-452-5	-	-	-	-	-
-5	40-19-41-2X	53-452-5	-	-	-	-	-
-6	40-19-22-2X	53-37-1	-	4-1-6051X	-	-	40-18-1-2X
-7	40-19-22-2X	53-452-3	62-453-4	4-1-6051X	-	40-17-1-44X	-
-8	40-19-22-2X	53-452-3	62-453-4	4-1-6051X	-	-	40-18-1-11X
-9	40-19-22-2X	53-452-3	62-453-4	4-1-6051X	-	-	40-18-1-12X
-10	40-19-22-2X	53-452-3	62-453-4	4-1-6051X	-	-	40-18-1-10X
-11	40-19-38-2X	53-452-4	53-453-2	3-4-8781	-	101-17-2-29X	-
-12	40-19-38-2X	53-452-4	53-453-2	53-106-2	-	-	-
-13	40-19-22-2X	53-452-3	62-453-4	4-1-6051X	-	101-17-2-29X	-
-14	40-19-43-2X	53-452-5	-	53-106-2	-	40-17-3-2X	-
-15	40-19-43-2X	53-452-5	-	53-106-2	-	40-17-3-2X	-
-16	40-19-43-2X	53-452-5	-	5-4-6321	-	101-17-2-29X	-
-17	40-19-53-2X	53-452-5	-	-	-	-	-
-18	40-19-53-2X	53-452-5	-	-	-	-	-
-19	40-19-43-2X	53-452-5	-	-	-	-	-
-20	40-19-41-2X	53-452-5	-	-	-	-	-
-21	40-19-22-2X	53-452-3	62-453-4	4-1-6051X	-	-	-
-22	40-19-39-2X	-	-	-	-	-	-
-23	40-19-43-2X	53-452-5	-	53-106-2	-	-	40-18-1-13X
-24	40-19-22-2X	53-452-3	-	-	-	-	-
-25	201-37-7	53-452-5	-	-	-	-	-
-26	201-37-7	53-452-5	-	-	-	-	-
-27	40-19-42-2X	53-452-5	-	-	-	-	-
-28	40-19-22-2X	53-452-3	62-453-4	4-1-6051X	-	-	-
-29	40-19-22-2X	53-452-3	62-453-4	4-1-6051X	-	-	-
-30	40-19-22-2X	53-452-3	-	-	-	-	-
-31	40-19-39-1X	-	-	-	-	-	-
-32	-	-	-	-	-	-	-
-33	40-19-38-2X	-	-	3-4-8781	-	-	-
-34	40-19-22-2X	-	-	6-1-6051X	-	101-17-2-2X	-
-35	40-19-43-2X	53-452-5	-	53-106-2	-	-	40-18-1-13X
-36	40-19-22-2X	53-452-3	62-453-4	4-1-6051X	-	-	-
-37	40-19-43-2X	53-452-5	-	3-4-8781	-	101-17-2-29X	-
-38	40-19-22-2X	53-452-3	62-453-4	4-1-6051X	-	-	-
-39	40-19-38-2X	53-452-3	62-453-4	4-4-4491	-	-	40-18-1-2X
-40	40-19-38-2X	53-37-1	-	53-106-2	-	-	40-18-1-2X
-41	40-19-42-2X	53-452-5	-	4-1-6051X	-	-	-
-42	40-19-22-2X	-	-	-	-	-	-
-43	40-19-53-2X	53-452-5	-	-	-	-	-
-44	40-19-38-2X	53-37-1	-	3-4-8781	-	-	-

MODEL ES43-5

TABULATED BILLS OF MATERIAL

T210-ES43-5

Tab No.	Used By	For Use With Clutch	CLUTCH HOUSING			Main Drive Gear	Drive Gear Bearing Cap F-1	Case Assembly G-1
			S A E	Assembly No. E-1	Rel. Code Pages			

Model ES43-5D
301634

-1	Never Released							
-2	Never Released							
-3	Navistar	Push Type	2	49-518-9-1X	-	49-35-17-1X	49-19-9-1X	49-15-6-1X
-4	Navistar	Push Type	2	49-518-9-1X	-	49-35-17-1X	49-19-9-1X	49-15-6-1X
-5	Navistar	Push Type	2	49-518-9-1X	-	49-35-17-1X	49-19-9-1X	49-15-6-1X
-6	Navistar	Push Type	2	49-518-9-1X	-	49-35-17-1X	49-19-9-1X	49-15-6-1X
-7	Ford	Push Type	-	49-360-5-1X**	-	49-35-16-1X	49-19-2-1X	49-15-8-1X
-8	Navistar	Push Type	2	49-518-9-1X	-	49-35-17-1X	49-19-9-1X	49-15-6-1X
-9	Direcspicer TSP	Push Type	2	49-518-9-1X	-	49-35-17-1X	49-19-9-1X	49-15-6-1X
-10	Service	Push Type	-	49-360-5-1X	-	49-35-19-1X	49-19-4-1X	49-15-6-1X
-11	Spicer Dr.Tr.	Pull Type	2	49-518-9-1X	-	49-35-20-1X	49-19-10-1X	49-15-6-1X
-12	OshKosh	Push Type	2	49-518-11-1X	-	49-35-17-1X	49-19-8-1X	49-15-6-1X
-13	Navistar	Push Type	2	49-518-9-1X	-	49-35-23-1X	49-19-9-1X	49-15-6-1X
-14	Navistar	Push Type	2	49-518-9-1X	-	49-35-23-1X	49-19-9-1X	49-15-6-1X
-15	Navistar	Push Type	2	49-518-9-1X	-	49-35-23-1X	49-19-9-1X	49-15-6-1X
-16	Ford	Push Type	2	49-360-5-1X	-	49-35-16-1X	49-19-2-1X	49-15-8-1X
-17	Navistar	Push Type	2	49-518-9-1X	-	49-35-17-1X	49-19-9-1X	49-15-6-1X
-18	Ford	Push Type	2	49-518-10-1X	-	49-35-17-1X	49-19-6-1X	49-15-6-1X
-19	Navistar	Push Type	2	49-518-9-1X	-	49-35-23-1X	49-19-9-1X	49-15-6-1X
-20	Ford	Pull Type	2	49-518-10-1X	-	49-35-20-1X	49-19-10-1X	49-15-6-1X
-21	Ford	Pull Type	2	49-518-10-1X	-	49-35-20-1X	49-19-10-1X	49-15-6-1X
-22	Spicer Dr.Tr.	Pull Type	2	49-518-9-1X	-	49-35-20-1X	49-19-10-1X	49-15-6-1X
-23	Spicer Dr. Tr.	Pull Type	2	49-518-9-1X	66	49-35-20-1X	49-19-10-1X	49-15-6-1X
-24	-	-	-	-	-	-	-	-
-25	Navistar	Push Type	2	49-518-9-1X	-	49-35-17-1X	49-19-9-1X	49-15-6-1X
-26	Navistar	Push Type	2	49-518-9-1X	-	49-35-23-1X	49-19-9-1X	49-15-6-1X

MODEL ES43-5

TABULATED BILLS OF MATERIAL

T210-ES43-5

Tab No.	Mainshaft Rear Brg. Cap Assembly H-1	Speedometer		End Yoke or Companion Flange	Shifter		
		Drive Gear or Signal Gear B-24	Driven Gear H-7		Housing Assembly	Lever & Dome Assembly Pages	Remote Control Pages

Model ES43-5D
301634

-1	Never Released						
-2	Never Released						
-3	40-19-43-2X	53-452-5	-	-	-	-	-
-4	40-19-42-2X	53-452-5	-	-	-	-	-
-5	40-19-41-2X	53-452-5	-	-	-	-	-
-6	40-19-22-2X	53-452-3	-	-	-	-	-
-7	40-19-39-1X	53-452-6	-	5-4-6481-1	-	-	-
-8	40-19-53-2X	53-452-5	-	-	-	-	-
-9	40-19-43-2X	53-452-5	-	53-106-2	-	-	-
-10	40-19-22-2X	53-452-3	-	-	-	-	-
-11	40-19-43-2X	53-452-5	-	4-4-4491-1	-	-	40-18-1-6X
-12	40-19-22-2X	53-452-3	62-453-4	4-1-6051X	-	-	-
-13	40-19-53-2X	53-452-5	-	-	-	-	-
-14	40-19-43-2X	53-452-5	-	-	-	-	-
-15	40-19-41-2X	53-452-5	-	-	-	-	-
-16	40-19-39-1X	-	-	-	-	-	-
-17	40-19-38-2X	53-452-3	-	-	-	-	-
-18	40-19-39-1X	-	-	-	-	-	-
-19	40-19-42-2X	53-452-5	-	-	-	-	-
-20	40-19-39-1X	53-452-6	-	5-4-6481-1	-	-	-
-21	40-19-39-2X	53-452-6	-	90-4-391-1	-	-	-
-22	40-19-43-2X	53-452-5	-	4-4-4491-1	-	-	40-18-1-9X
-23	40-19-38-2X	53-37-1	-	4-4-4491-1	-	-	-
-24	-	-	-	-	-	-	-
-25	-	53-452-5	-	-	-	-	-
-26	-	53-452-5	-	-	-	-	-

BACK-TAPER CHANGEOVER KITS FOR ES43-5 TRANSMISSIONS

Kits will be available November 25, 1996

ES43-5, A Ratio, 4/5 Shift Rail, Kit 49-35-16-3X

		<u>Old Drive Gear</u>	<u>New Drive Gear</u>	<u>Order Kit #</u>
Drive Gear	49-35-16	49-35-1	49-35-16	49-35-16-3X
M/S 4th Gear	49-8-18	49-35-3	49-35-17	49-35-17-4X
Synchronizer	101-464-1X	49-35-4	49-35-18	49-35-18-3X
Clutch Gear	49-466-4	49-35-5	49-35-19	49-35-19-3X
Shift Rail Assembly	49-69-1X	49-35-6	49-35-20	49-35-20-3X
Poppet Plunger	101-438-9	49-35-8	49-35-21	49-35-21-3X
Poppet Spring	101-72-7	49-35-10	49-35-22	49-35-22-3X
Identification Tag	NP-204	49-35-11	49-35-23	49-35-23-3X

Above Kits are the same except for the Drive Gear.
See Kit part list left.

ES43-5, D Ratio, 4/5 Shift Rail, Kit 49-35-16-4X

		<u>Old Drive Gear</u>	<u>New Drive Gear</u>	<u>Order Kit #</u>
Drive Gear	49-35-16	49-35-1	49-35-16	49-35-16-4X
M/S 4th Gear	49-8-19	49-35-3	49-35-17	49-35-17-5X
Synchronizer	101-464-1X	49-35-4	49-35-18	49-35-18-4X
Clutch Gear	49-466-4	49-35-5	49-35-19	49-35-19-4X
Shift Rail Assembly	49-69-1X	49-35-6	49-35-20	49-35-20-4X
Poppet Plunger	101-438-9	49-35-8	49-35-21	49-35-21-4X
Poppet Spring	101-72-7	49-35-10	49-35-22	49-35-22-4X
Identification Tag	NP-204	49-35-11	49-35-23	49-35-23-4X

Above Kits are the same except for the Drive Gear.
See Kit part list left.

ES43-5, A & D Ratio, 2/3 Shift Rail, Kit 49-8-20-3X

M/S 3rd Gear	49-8-20
M/S 2nd Gear	49-8-21
Synchronizer	49-464-1X
Clutch Gear	101-466-7
Shift Rail Assembly	49-69-2X
Poppet Plunger	101-438-9
Poppet Spring	101-72-7
Identification Tag	NP-204

Note: Due to the nature of back-tapered clutching teeth, the straight toothed parts are not interchangeable with back-tapered parts. The entire kit must be installed so that a given rail has parts that have either straight toothed clutching teeth or back-tapered clutching teeth. Do not mix straight toothed parts with back-tapered parts.

Printed in U.S.A.



14700 Helm Court
Plymouth, MI 48170
(800) 401-9866 or (734) 456-3770
Fax: (734) 456-3739
www.ttcautomotive.com

